

K-no.: 26654	1000 A Current Sensor for $\pm 24V$ - Supply Voltage for electric current measurement: DC, AC, pulsed, mixed ..., with a galvanic isolation between primary circuit (high power) and secondary circuit (electronic circuit)	Date 06.05.2019
Customer: Standard Type	Customer Part number	Seite 1 von 6

Electrical data

I_{PN}	Primary nominal r.m.s. current	1000	A
R_M^1	Measuring resistance	0 ... 100	Ω
I_{SN}	Secondary nominal r.m.s. current	200	mA
K_N	Turns ratio	(1): 5000	

¹ connected to sensor output, R_M for $I_{P,max}$ see fig. 1 on page 2

Accuracy – Dynamic performance data

		min.	typ.	max.	Unit
$I_{P,max}^2$	Max. measuring range @ $R_M = 10 \Omega$; $T_A = 25^\circ C$	2500	-	-	A
	@ $R_M = 10 \Omega$; $T_A = 85^\circ C$	2150	-	-	A
X	Accuracy @ I_{PN} , $T_A = -40 \dots +85^\circ C$	-	-	0.4	%
ϵ_L	Linearity	-	-	0.1	%
I_0	Offset current @ $I_P=0$, $T_A = 25^\circ C$	-	-	0.1	mA
I_{OH}	Hysteresis current	-	-	0.1	mA
t_r	Response time @ 80% of I_{PN}	-	< 1	-	μs
t_{ra}	Reaction time @ 10% of I_{PN} ($di/dt = 1200 A/\mu s$)	-	-	1	μs
f_{BW}	Frequency bandwidth	DC...100	-	-	kHz

²currents with high slew rates can be measured above $I_{P,max}$ (transformer behavior)

General data

		min.	typ.	max.	Unit
ϑ_A	Ambient operating temperature	-40	-	+85	$^\circ C$
ϑ_S	Ambient storage temperature	-40	-	+85	$^\circ C$
m	Mass	-	550	-	g
U_C	Supply voltage	± 21.60	± 24	± 25.2	V
I_{C0}	Current consumption for $I_P = 0A$	-	27	-	mA
I_{CN}	Current consumption for $I_{PN} = 1000A$	-	190	-	mA
* S_{clear}	Clearance	20	-	-	mm
* S_{creep}	Creepage	20	-	-	mm
* U_{sys}	System voltage (determines impulse voltage acc. table 7)	-	-	1000	V_{RMS}
* U_{AC}	Working voltage (acc. U_{ACL} as limit in table 3)	-	-	1000	V_{RMS}
		-	-	1500	V_{DC}
* U_{PD}	Rated discharge voltage (acc. table 24 with $U_{PD}=U_{ACP}$)	-	-	1414	V_{peak}
	Max. potential difference acc. to UL 508	-	-	1000	V_{rms}

* Constructed and manufactured and tested in accordance with EN 61800-5-1:2007 (Pin 1 - 3 to primary opening)
Reinforced insulation, Insulation material group 1, Pollution degree 2, Overvoltage category III

Date	Name	Issue	Amendment
06.05.19	Sn.	81	Mechanical outline changed. Add position of plug. Minor change
25.11.16	Ku.	81	Typo: Page 2, Table 55 $^\circ C/1\Omega/2880A$ changed Dwell time from <10min to <3min. minor change.

Hrg R&D-PD NPI D editor	Bearb: Ockajak designer		MC-PM: Sn. check	freig.: SB released
----------------------------	----------------------------	--	---------------------	------------------------

Weitergabe sowie Vervielfältigung dieser Unterlage, Verwertung und Mitteilung ihres Inhalts nicht gestattet, soweit nicht ausdrücklich zugestanden. Zuwiderhandlungen verpflichten zu Schadenersatz. Alle Rechte für den Fall der Patenterteilung oder GM-Eintragung vorbehalten

K-no.: 26654	1000 A Current Sensor for ±24V- Supply Voltage for electric current measurement: DC, AC, pulsed, mixed ..., with a galvanic isolation between primary circuit (high power) and secondary circuit (electronic circuit)	Date 06.05.2019
--------------	--	-----------------

Customer: Standard Type	Customer Part number	Seite 2 von 6
-------------------------	----------------------	---------------

**Capability of the sensor for measuring max. peak currents at defined temperatures,
values for supply voltage ±22.80 V (±24 V -5 %):**

Θ_A	55 °C	55 °C	55 °C	55 °C	85 °C	85 °C	85 °C	85 °C
R_M	1 Ω	5 Ω	20 Ω	50 Ω	1 Ω	5 Ω	20 Ω	50 Ω
$I_{P,max}$	2880A	2610A	1930A	1270A	2610A	2390A	1810A	1220A
Dwell time	< 3min	< 10min	< 10min	< 30min	< 3min	< 3min	< 3min	< 15min

Limit curve of measurable current $\hat{I}_P=f(R_M)$, values for supply voltage ±22.80 V (±24 V -5 %)

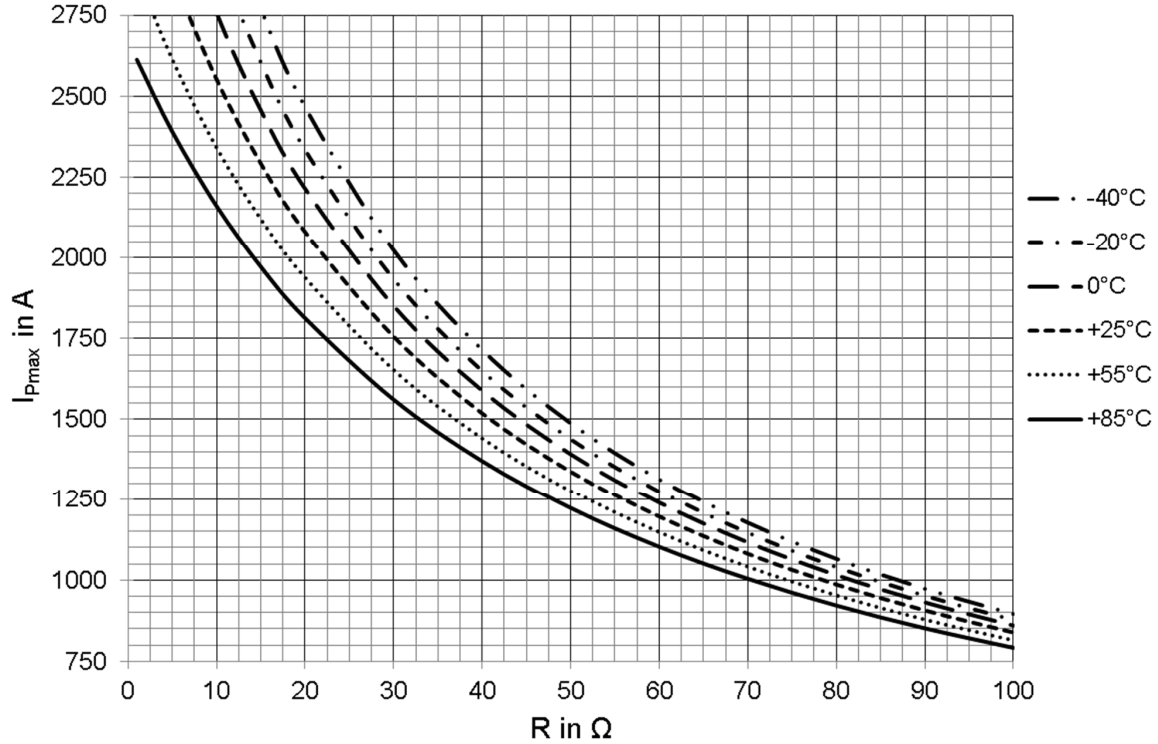

Fig. 1: $I_{P,max} = f(R_M) @ \vartheta_A$

Absolute maximum conditions:

Θ_A	$\leq 70\text{ °C}$	$70\text{ °C} < \vartheta_A \leq 85\text{ °C}$
$I_P = I_{P,max}$ up to	1800 A _{DC}	1200 A _{DC}

Stresses above these conditions may cause permanent damage. Exposure to absolute maximum rating conditions for extended periods will degrade device reliability and lifetime expectancy. Functional operation of the device at these or any other conditions beyond those specified in this specification is not permitted.

Hrg R&D-PD NPI D editor	Bearb: Ockajak designer		MC-PM: Sn. check		freig.: SB released
----------------------------	----------------------------	--	---------------------	--	------------------------

Weitergabe sowie Vervielfältigung dieser Unterlage, Verwertung und Mitteilung ihres Inhalts nicht gestattet, soweit nicht ausdrücklich zugestanden. Zuwiderhandlungen verpflichten zu Schadenersatz. Alle Rechte für den Fall der Patenterteilung oder GM-Eintragung vorbehalten

K-no.: 26654

1000 A Current Sensor for $\pm 24V$ - Supply Voltage

Date 06.05.2019

for electric current measurement:
DC, AC, pulsed, mixed ..., with a galvanic isolation between
primary circuit (high power) and secondary circuit (electronic circuit)

Customer: Standard Type

Customer Part number

Seite 3 von 6

Overload puls (μs -range)

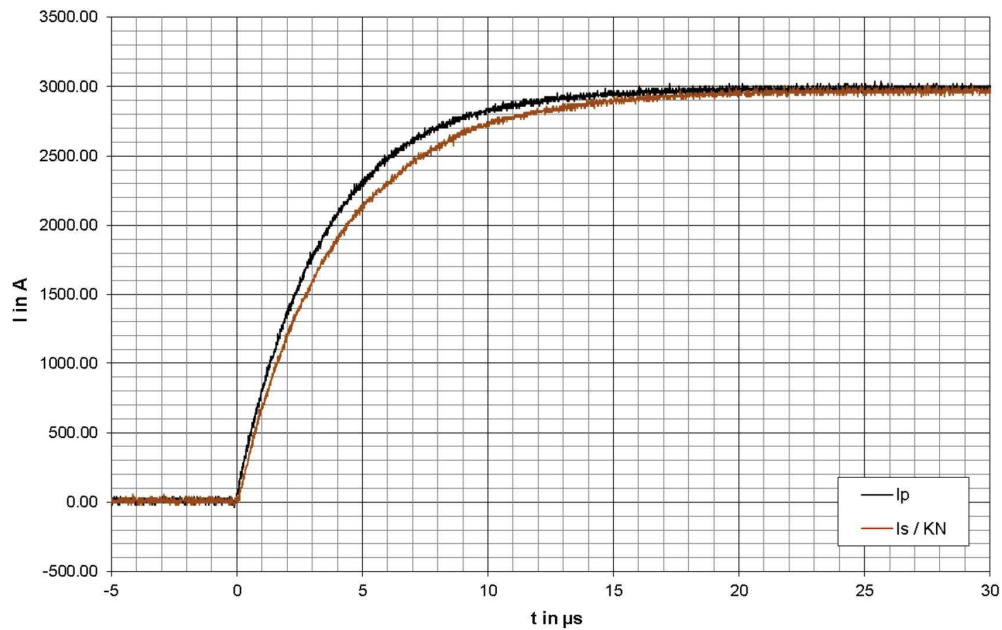
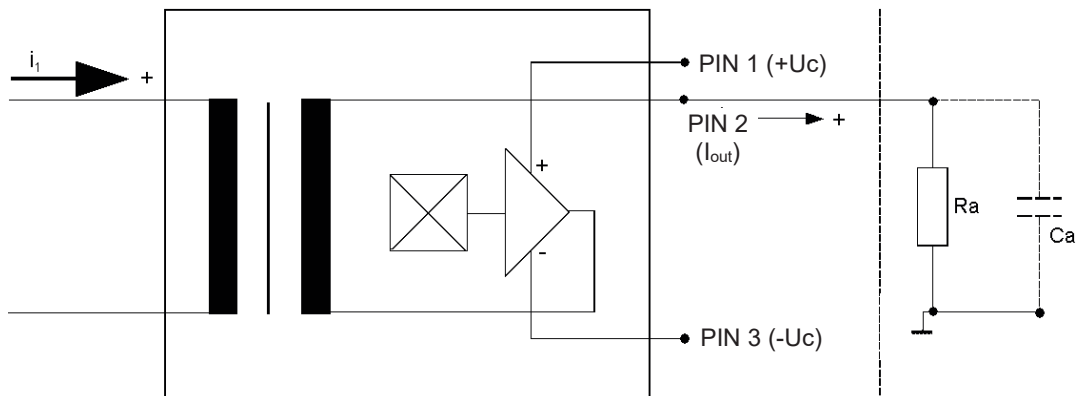

Fig. 2: Output current reaction of a 3kA current pulse with $R_M = 10\Omega$

Schematic diagram:



Hrg R&D-PD NPI D
editor

Bearb: Ockajak
designer

[Signature]

MC-PM: Sn.
check

freig.: SB
released

Weitergabe sowie Vervielfältigung dieser Unterlage, Verwertung und Mitteilung ihres Inhalts nicht gestattet, soweit nicht ausdrücklich zugestanden. Zuwiderhandlungen verpflichten zu Schadenersatz. Alle Rechte für den Fall der Patenterteilung oder GM-Eintragung vorbehalten

K-no.: 26654	1000 A Current Sensor for $\pm 24V$ - Supply Voltage for electric current measurement: DC, AC, pulsed, mixed ..., with a galvanic isolation between primary circuit (high power) and secondary circuit (electronic circuit)	Date 06.05.2019
--------------	--	-----------------

Customer: Standard Type	Customer Part number	Seite 4 von 6
-------------------------	----------------------	---------------

Mechanical outline (mm):

*General tolerances DIN ISO 2768-c

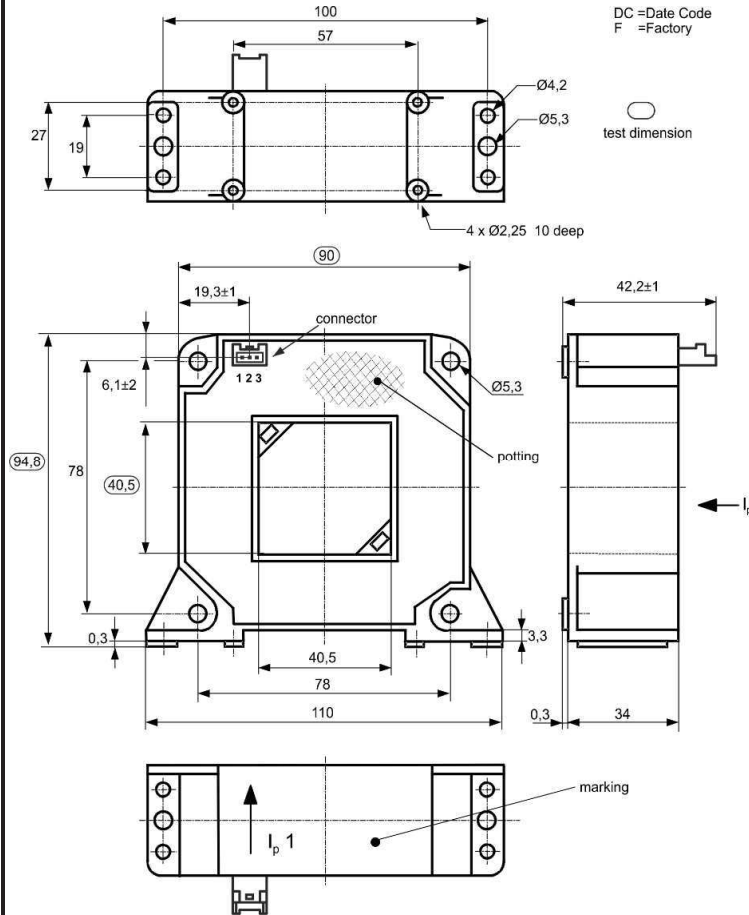

Connector:
JST BH03B-XASK-BN

Pin 1: $+U_C$
Pin 2: I_{out}
Pin 3: $-U_C$

I_p : Positive current direction

Marking

Explanation: Item number: see Tab.2 (left column)
F = Factory code
DC = Date code

Example: Sensor with end number X152
Produced in Slovakia in April 2015
→ Part number: 4640-X152
→ Factory code: SK
→ Date code: F4

Arrow shows positive current direction VAC logo

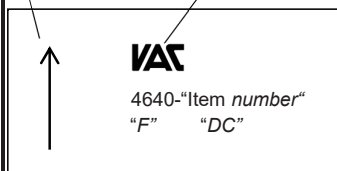

Hrg R&D-PD NPI D editor	Bearb: Ockajak designer	MC-PM: Sn. check	freig.: SB released
-------------------------	-------------------------	------------------	---------------------

Weitergabe sowie Vervielfältigung dieser Unterlage, Verwertung und Mitteilung ihres Inhalts nicht gestattet, soweit nicht ausdrücklich zugestanden. Zuwiderhandlungen verpflichten zu Schadenersatz. Alle Rechte für den Fall der Patenterteilung oder GM-Eintragung vorbehalten

K-no.: 26654	1000 A Current Sensor for ±24V- Supply Voltage for electric current measurement: DC, AC, pulsed, mixed ..., with a galvanic isolation between primary circuit (high power) and secondary circuit (electronic circuit)	Date 06.05.2019
Customer: Standard Type	Customer Part number	Seite 5 von 6

Offset ripple reduction

The offset ripple can be reduced by an external low pass. The simplest solution is a passive low pass filter of 1st order by connecting a capacitor parallel to the burden resistor R_M as shown on page 3. The required capacitance can be calculated as follows:

$$C_a = \frac{1}{2\pi \cdot R_M \cdot f_g}$$

In this case the response time is enlarged. It is calculated from:

$$t'_r \geq t_r + 2,5R_M C_a$$

Routine Test (Measurement after temperature balance of the samples at room temperature; SC = significant characteristic)

$K_N(N_1/N_2)$	(100%) M3011/6	Transformation ratio ($I_{PN}=1000A$, 40-80 Hz)	1 : 5000 ± 0.4	% (SC)
I_0	(100%) M3226	Offset current	< 0.1	mA (SC)
U_P	(100%) M3014	Test voltage (1s) Pin 1 - 3 to primary opening	(RMS) 4.0	kV (SC)
U_{PDE}	(AQL 1/S4)	Partial discharge voltage (extinction)	(RMS) 1500	V
$U_{PD(rms)} \cdot 1.875$		*acc. table 24	(RMS) 1875	V

Type Test (Pin 1-3 to primary opening)

\dot{U}_W	M3064	HV transient test, *acc. table 18, 19 (1.2 µs / 50 µs-wave form)	12	kV
U_P	M3014	Test voltage (5s)	(RMS) 6	kV
U_{PDE}		Partial discharge voltage (extinction)	(RMS) 1500	V
$U_{PD(rms)} \cdot 1.875$		*acc. table 24	(RMS) 1875	V
ESD	EN 61000-4-2	contact / surface	±8 / ±15	kV

* IEC61800-5-1:2007.

Applicable documents

Constructed, manufactured and tested in accordance with IEC61800-5-1:2007.

Further standards:-UL 508 ; file E317483, category NMTR2 / NMTR8

Hrg R&D-PD NPI D editor	Bearb: Ockajak designer		MC-PM: Sn. check		freig.: SB released
----------------------------	----------------------------	--	---------------------	--	------------------------

Weitergabe sowie Vervielfältigung dieser Unterlage, Verwertung und Mitteilung ihres Inhalts nicht gestattet, soweit nicht ausdrücklich zugestanden. Zuwiderhandlungen verpflichten zu Schadenersatz. Alle Rechte für den Fall der Patenterteilung oder GM-Eintragung vorbehalten

K-no.: 26654	1000 A Current Sensor for ±24V- Supply Voltage for electric current measurement: DC, AC, pulsed, mixed ... with a galvanic isolation between primary circuit (high power) and secondary circuit (electronic circuit)	Date 06.05.2019
--------------	---	-----------------

Customer: Standard Type	Customer Part number	Seite 6 von 6
-------------------------	----------------------	---------------

Explanation to parameters used in this datasheet

Accuracy

$X_{total}(I_{PN})$: The sum of all possible errors over the temperature range by measuring a current I_{PN} :

$$X_{total} = 100 \cdot \left| \frac{I_S(I_{PN})}{K_N \cdot I_{PN}} - 1 \right|$$

X: Permissible measurement error in the final inspection at RT. I_{SB} is the DC output current for a DC primary current with the same value as the (positive) rated current I_{PN} (with $I_O = 0$)

$$X = 100 \cdot \left| \frac{I_{SB}}{I_{SN}} - 1 \right|$$

X_{Ti} : Temperature drift of the rated value orientated output term. I_{SN} (cf. Notes on F_i) in a specified temperature range: I_{SB} is the secondary current at temperature ϑ_{A1} or ϑ_{A2}

$$X_{Ti} = 100 \cdot \left| \frac{I_{SB}(\vartheta_{A2}) - I_{SB}(\vartheta_{A1})}{I_{SN}} \right|$$

ϵ_L : Linearity fault where I_P is any input DC and I_{Sx} the corresponding output term. ($I_O = 0$).

$$\epsilon_L = 100 \cdot \left| \frac{I_P}{I_{PN}} - \frac{I_{Sx}}{I_{SN}} \right|$$

Offset and drift

I_{OH} : Zero variation after overloading with a DC of tenfold the rated value ($R_M = R_{MN}$)

I_{oi} : Long term drift of I_O after 100 temperature cycles in the range -40 to 85 °C.

Dynamic properties

t_{ra} Reaction time, measured as a delay time between a rectangular primary current ($di/dt \approx 1200A/\mu s$) and the output current I_S at $I_P = 0.1 \cdot I_{PN}$

t_r : Response time, measured as a delay time between a rectangular primary current and the output current I_S at $I_P = 0.9 \cdot I_{PN}$

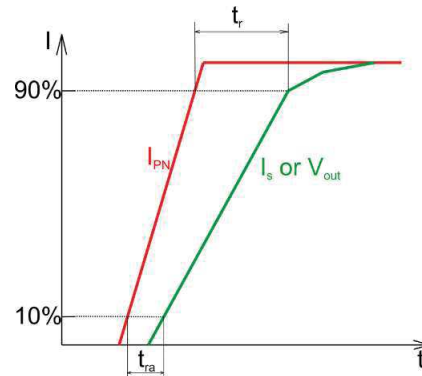

Voltage ratings (according to IEC 61800-5-1:2007)

U_{PD} Rated discharge voltage (recurring peak voltage separated by the insulation)

U_{sys} System voltage: RMS value of rated voltage

U_{AC} Working voltage: RMS voltage which occurs by design in a circuit or across an insulation

Hrg R&D-PD NPI D editor	Bearb: Ockajak designer		MC-PM: Sn. check		freig.: SB released
-------------------------	-------------------------	--	------------------	--	---------------------