

K-No.: 26829

Differential Current Sensor for IC-CPD acc. to the standard UL2231



Date: 11.10.2021

Customer: Standard type

Page 1 of 7

Description

- Fluxgate current sensor with toroidal core
- PCB mounting

Characteristics

- Excellent accuracy
- AEC-Q qualified components
- Switching open-collector outputs
- Compact design

Applications

Mainly used for obile applications:

- IC-CPD acc. To IEC62752

Patents: EP2571128 / US9397494 / CN103001175 // EP2813856

Electrical data – Ratings

		min.	typ.	max.	Unit
I_P	Primary nominal RMS current (1phase)			20	A
$I_{\Delta N1}$	Rated residual operating current 1		5		mA rms
$I_{\Delta N2}$	Rated residual operating current 2		20		mA rms
$I_{\Delta N1, tolerance}$	Trip tolerance 1	4	5	6 ⁽¹⁾ / 12 ⁽²⁾	mA rms
$I_{\Delta N2, tolerance}$	Trip tolerance 2	15		20 ⁽¹⁾ / 50 ⁽²⁾	mA rms
$S_{PWM-OUT}$	Scaling factor of the rms component $I_{\Delta N1}$ (for monitoring purpose only!)		2		%/mA
$I_{\Delta RI, 1/2}$ (Fig.1)	Recovery current level for $I_{\Delta N1}/I_{\Delta N2}$ (absolute value rms)		2 / 10		mA

(1) f = dc to 1kHz (2) f = 1kHz to 2kHz

Accuracy – Dynamic performance data

$I_{\Delta N, max}$	Measuring range (peak)	-300		+300	mA
X	Resolution (@ $I_{\Delta N}$, $\Theta_A = 25^\circ C$)		< 0.2		mA
t_r (Fig.3)	Response time	< $(20/I_{\Delta})^{1,43} - 10ms$ (According to UL2231-2 Ed. 2)			
f_{BW} (Fig. 4)	Frequency range	DC		2	kHz

General data

ϑ_A	Ambient operation temperature	-40		85	°C
$\vartheta_{Storage}$	Ambient storage temperature ⁽³⁾	-40		85	°C
m	Mass		26		g
V_{CC}	Supply voltage	4.8	5	5.2	V
I_{CC}	Supply current	38		45	mA rms
$S_{clear, pp}$	Clearance (primary to primary)		>1.94		mm
$S_{creep, pp}$	Creepage (primary to primary)		>2.50		mm
$S_{clear, ps}$	Clearance (primary to secondary) ⁽⁵⁾		>3.87		mm
$S_{creep, ps}$	Creepage (primary to secondary) ⁽⁵⁾		>5.00		mm
FIT	EN/IEC 61709 / SN 29500 ⁽⁵⁾ (MIL-HDBK-217F) ⁽⁵⁾		1529 (6349)		fit

⁽³⁾ see M_sheet 3101; storage temperature inside cardboard packaging

⁽⁴⁾ Isolated wires are preferred. If isolated primary conductors are used, the isolation coordination is according to:
Reinforced insulation, Insulation material group 1, Pollution degree 2, Sea-Level ≤ 4000m and overvoltage category II.

⁽⁵⁾ The results are valid under following conditions: 55°C mean component ambient temperature by continuous operation (8760h per year);
Environment condition: ground mobile, no dust or harmful substances, according to IEC61709; Fit equals one failure per 10⁹ component hours.

General description of sensor function:

The Sensor is sensitive to AC and DC current and can be used for fault current detection in IC-CPD applications. The Sensor detects AC fault currents according to UL2231-2 Ed.2. In the event of an AC fault current (5mA rms), PIN 3 will change it's state from a low level (GND) to high impedance level. In the event of an AC fault current (20mA rms), PINs 3 and 4 will change state from a low level (GND) to a high impedance level.

Error conditions (e.g. an internal error) are signaled on PIN 1 (ERROR-OUT).

Datum	Name	Index	Änderung
11.10.2021	BZ	83	Patents added on sheet 1. CN-21-290
28.03.19	BZ	83	Sheet 2. Marking changed from VAC to benvac. CN-19-062
Editor.: R&D-PD-NPI D		Designer: MB	MC-PM: BZ
			Released by: SB

Differential Current Sensor for IC-CPD acc. to the standard UL2231



Date: 11.10.2021

K-No.: 26829

Customer: Standard type

Page 2 of 7

Mechanical outline (mm):

General tolerances DIN ISO 2768-c

Connections:

PIN no. 1-8: 0.46mm x 0.46mm
PIN no. 9-14: Ø = 1.8mm

Marking:

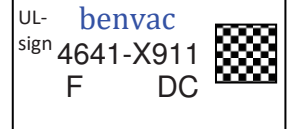

Content of Data-Matrix-Code is: **benvac**, 4641-X911, F, DC

Datecode Format: [YWW]
Example: J04: 2017, Week 4

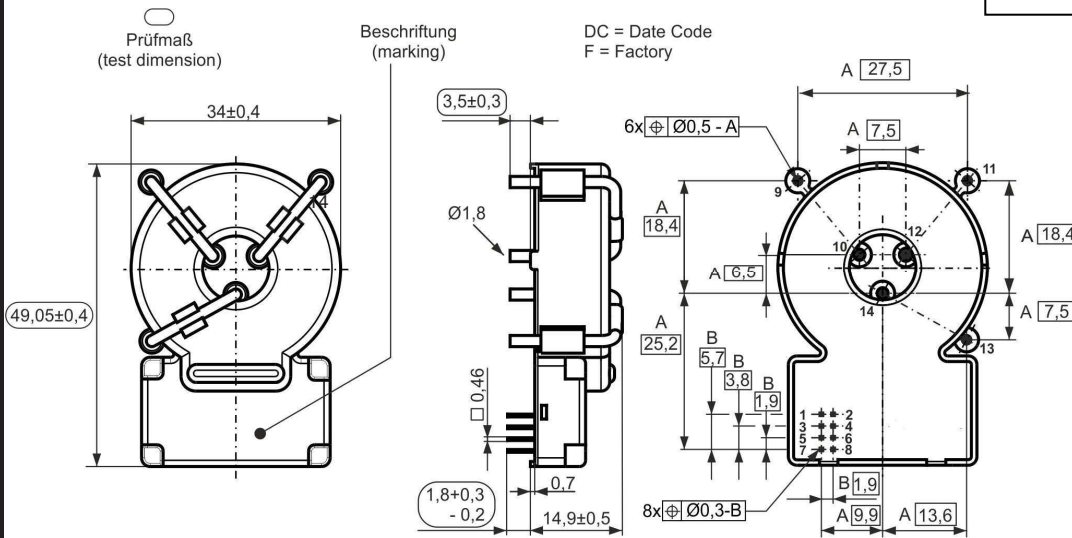

PIN description:

PIN No.	Description
PIN 1 → ERROR-OUT (open collector output)	If no system fault is detected, the output PIN 1 is a low level (GND). If a system fault is detected, PIN 1 is high impedance. In this case, PINS 3 and 4 will be set to a high impedance state (see tab. 1).
PIN 2 → TEST-IN (refer to Fig. 2)	A function test including an offset measurement (this value is stored in EEPROM for further calculation) is activated if this PIN is connected to GND for a period of 30ms to 1.2s. If the PIN is set to GND less than 30ms or more than 1.2s, no function test will be performed. Attention: During the functional test and offset measurement, no differential current may flow. To ensure high accuracy of the sensor this test should be activated at regular intervals (e.g. at startup, before measuring...). If a push-pull switch is used, the voltage range must be 0V...5V.
PIN 3 → X5-OUT (open collector output)	If the residual current is below 5mA rms and no system fault occurs the output on PIN 3 is a low level (GND). In any other case output PIN 3 is in a high impedance state. If PIN 4 is high impedance, PIN 3 will also be set to high impedance (see tab. 1).
PIN 4 → X20-OUT (open collector output)	If the residual current is below the 20mA rms and no system fault occurs the output on PIN 4 is a low level (GND). In any other case PINS 3 and 4 is in a high impedance state (see tab. 1).
PIN 5 → GND	Ground connection
PIN 6 → VCC	Positive supply voltage
PIN 7 → PWM-OUT	Acc. to the rms component of residual current a duty-cycle with f=8kHz is generated. This is for monitoring purposes only and is not safety function! Refer to $S_{PWM-OUT} = 2\%/mA$
PIN 8 → N.C.	Not connected
PIN 9 – 14	For primary wires connection

Differential Current Sensor for IC-CPD acc. to the standard UL2231



Date: 11.10.2021

K-No.: 26829

Customer: Standard type

Page 3 of 7

Typical application diagram:

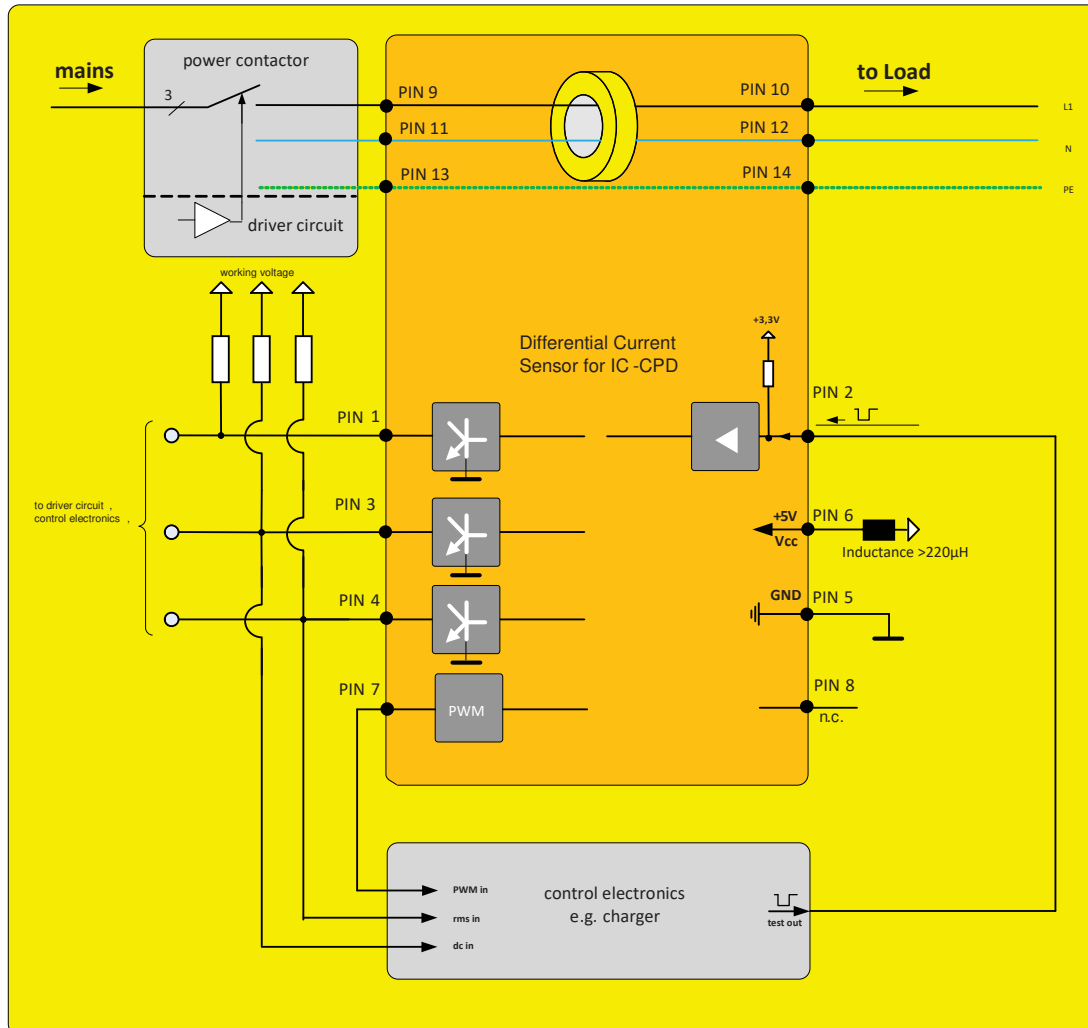

Absolute maximum Ratings⁽⁶⁾:

V_{CE}	Collector-Emitter voltage (PINs 1, 3 and 4)	40	V
I_C	Collector current (PINs 1, 3 and 4)	50	mA
V_{CC}	Maximum supply voltage (without function)	-0.3	7
U_{MAX}	Maximum rated voltage of primary conductors	250	V
$V_{TEST-IN, low}$	TEST-IN Input Voltage, low level	0	0.6
$V_{TEST-IN, high}$	TEST-IN Input Voltage, high level	2.5	5

⁽⁶⁾Stresses above these ratings may cause permanent damage.
 Exposure to these conditions for extended periods may degrade device reliability.
 Functional operation of the device at these or any other conditions beyond those specified is not supported.



Differential Current Sensor for IC-CPD acc. to the standard UL2231

Date: 11.10.2021

K-No.: 26829

Customer: Standard type

Page 4 of 7

Final Tests: (Measurements after temperature balance of the samples at room temperature, SC=significant characteristic)

		Min.	Max.	Unit
Vcc	Supply voltage	4.9	5.1	V
Icc	Supply current	38.0	45.0	mA
TEST-IN (SC)	TEST-IN voltage	2.8	3.3	V
X5-OUT (normal)	X5-OUT voltage	0	0.6	V
X20-OUT (normal)	X20-OUT voltage	0	0.6	V
ERROR-OUT (normal)	ERROR-OUT voltage	0	0.6	V
X5-OUT (activated)	X5-OUT voltage activated @5V, 1kΩ (pull-up)*	4.9	5.1	V
X20-OUT (activated)	X20-OUT voltage activated @5V, 1kΩ (pull-up)*	4.9	5.1	V
ERROR-OUT (activated)	ERROR-OUT voltage activated @5V, 1kΩ (pull-up)*	4.9	5.1	V
TC1	Trip current 1 – X5	4.1	5.4	mA
TC2	Trip current 2 – X20	14	20	mA
PWM-OUT (frequency)	PWM-OUT frequency	7.8	8.2	kHz
PWM-OUT (duty-cycle)	PWM-OUT duty-cycle @6mA DC	11	13	%
LV1	Limit values of break time - X5-OUT@6mA, 60Hz	0	700	ms
LV2	Limit values of break time - X5-OUT@30mA, 60Hz	0	700	ms
LV3	Limit values of break time - X20-OUT@20mA, 60Hz	0	1000	ms
LV4	Limit values of break time - X20-OUT@100mA, 60Hz	0	100	ms

* the maximum values of collector-emitter voltage and current see "Absolute maximum ratings"

Product Tests:

	Acc. to VAC sheet M3238 Following tests differ from M3238: 3.4a: Rapid change of Temperature for 300 cycles 4.5a: Damp heat, steady state. Duration: 1000 h	passed
PD	IEC61000-4-1, EN60270, M3024 UPDE M3024, Partial discharge voltage (extinction) *acc. to table 24	1.5 kV rms
ESD	Air- and contact discharge; U=±2000V, R=1500Ω, C=100pF Acc. to Human Body Model JESD22-A114	±2.0 kV
EMC	IEC61000-4-3 (Radiated, radio-frequency, electromagnetic field immunity) 20V/m 80MHz – 1GHz 80%AM 1kHz, recommend with the use of inductance of >220μH in series of Vcc input.	passed
	CISPR 14-1 (Immunity to conducted disturbances), recommend with the use of inductance of >220μH in series of Vcc input.	passed
	IEC61000-6-4 (Emission standard for industrial environments, conducted disturbances)	Should be done in end application
A , Φ	Amplitude and phase response over frequency 1% of I _{PN} or I _{Δn}	passed
Impulse test	Monitoring of CS function during the current phase test 100A to 5kA	passed

K-No.: 26829

Differential Current Sensor for IC-CPD acc. to the standard UL2231



Date: 11.10.2021

Customer: Standard type

Page 5 of 7

Requalification Tests: (replicated every year, Precondition acc. to M3238)

$\hat{U}_{W, \text{prim-sec}}$	M3064	Impulse test (1.2 μ s/50 μ s waveform) PIN 1-8 vs. PIN 9-16 5 pulse \rightarrow polarity +, 5 pulse \rightarrow polarity -	5.5	kV rms
$\hat{U}_{W, \text{prim-prim}}$	M3064	Impulse test (1.2 μ s/50 μ s waveform) PIN 9 vs. PIN 11, PIN 11 vs. PIN 13, PIN 13 vs. PIN 15, PIN 15 vs. PIN 9 5 pulse \rightarrow polarity +, 5 pulse \rightarrow polarity -	4.0	kV rms
U_d	M3014	Test voltage, 60s PIN 1-8 vs. PIN 9-16	1.5	kV rms
$U_d, \text{prim-prim}$	M3014	Test voltage between primary conductors, 5s PIN 9 vs. PIN 11, PIN 11 vs. PIN 13, PIN 13 vs. PIN 15, PIN 15 vs. PIN 9	1.5	kV rms
U_{PDE}	M3024	Partial discharge voltage (extinction) PIN 1-8 vs. PIN 9-14 *acc. to table 24	1.2	kV rms
$U_{PD} \times 1.875$	M3024	Partial discharge voltage (extinction) PIN 1-8 vs. PIN 9-14 *acc. to table 24	1.5	kV rms

* IEC 61800-5-1:2007

Other instructions:

- Temperature of the primary conductor should not exceed 105°C.
- Housing and bobbin material UL-listed, flammability class 94V-0.
- Vcc during Test-In-Function must be at least 4.8V
- Fall- and rise-time of Vcc 2...50 μ s/V

Figures:

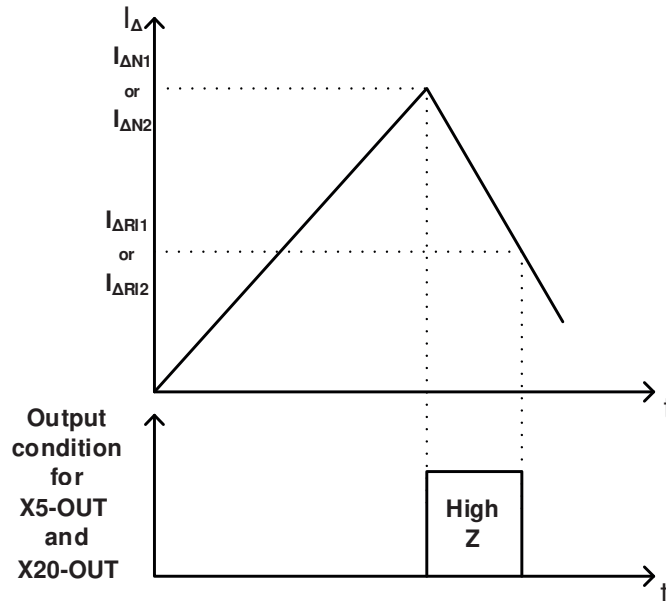

Fig. 1: Meaning of switching recovery level

If the trip-level $I_{\Delta N1}/I_{\Delta N2}$ is accomplished the outputs X5-OUT/X20-OUT will change their state from low-level (GND) to high impedance. Depending on the existence of the residual current I_{Δ} , the outputs X5-OUT/X20-OUT will remain in this state until I_{Δ} falls below the threshold $I_{\Delta RI1}/I_{\Delta RI2}$.

Differential Current Sensor for IC-CPD acc. to the standard UL2231



Date: 11.10.2021

K-No.: 26829

Customer: Standard type

Page 6 of 7

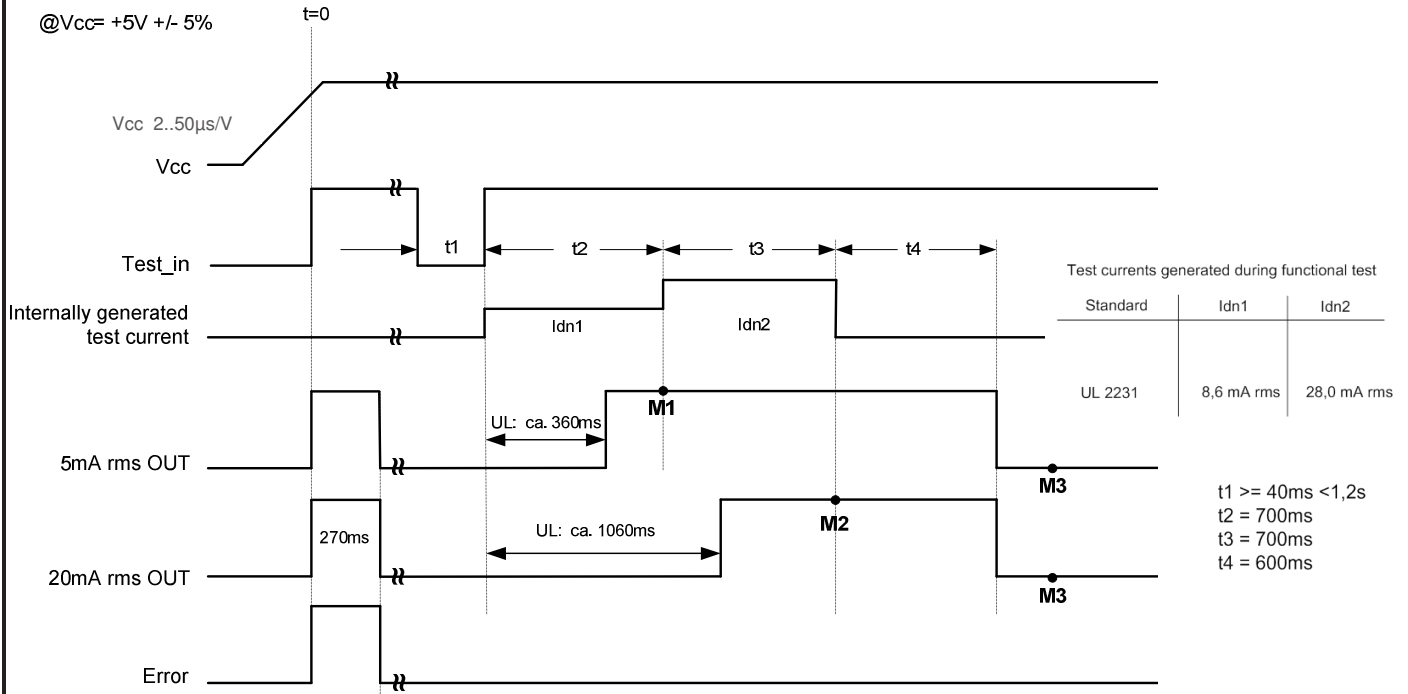

After activating the test sequence, the end product has to monitor the correct state of the switching outputs being used at the following points in time

- M1: check that 5mA rms OUT is disabled (latest time)
- M2: check that 20mA rms OUT is disabled
- M3: check that 20mA rms OUT resp. 5mA rms OUT is enabled

Fig. 2: Power-Up timing diagram

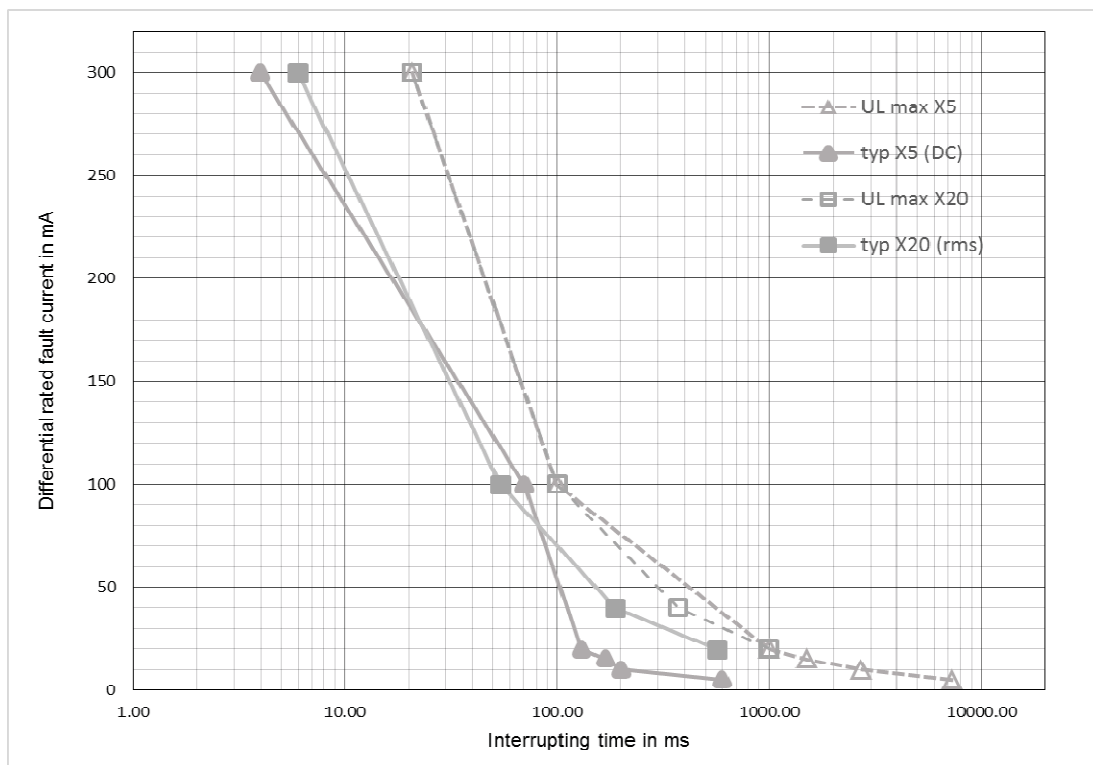

Fig. 3: Interrupting Time according to UL2231-2 Ed.2, page 30, fig. 6 and typical values of sensor

Differential Current Sensor for IC-CPD acc. to the standard UL2231



Date: 11.10.2021

K-No.: 26829

Customer: Standard type

Page 7 of 7

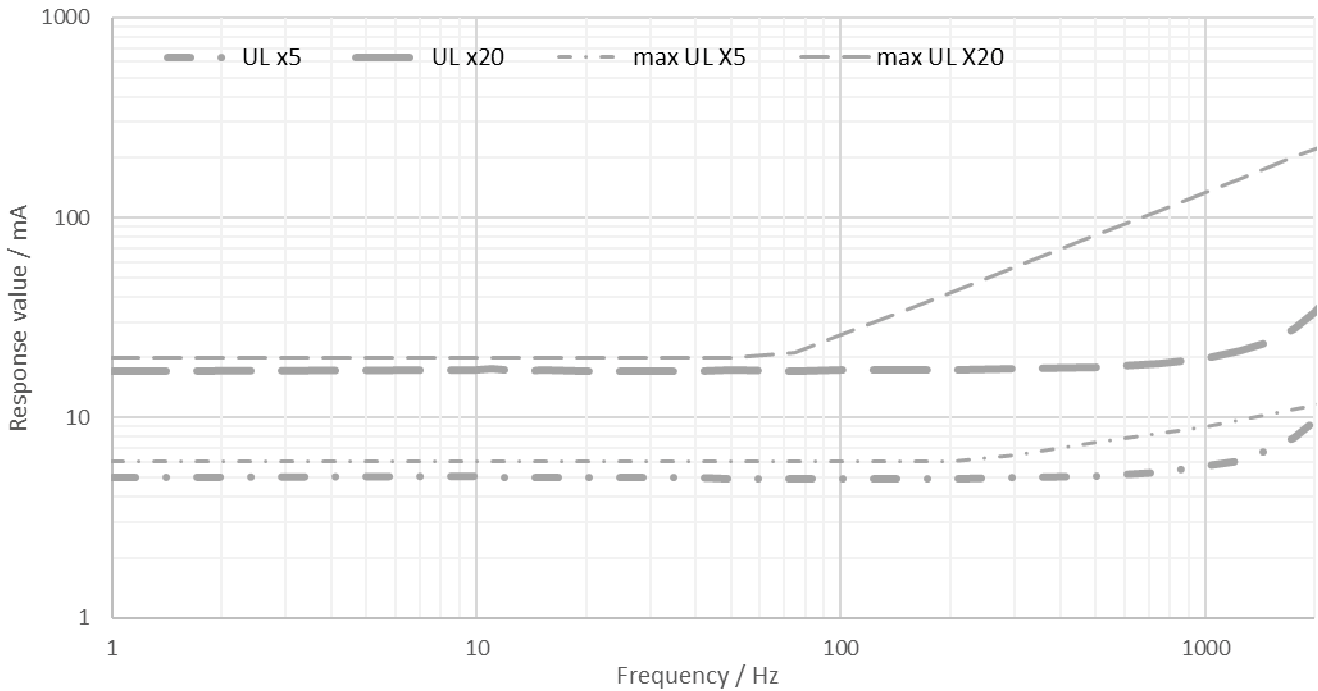

Fig. 4: Response value over frequency

X5-OUT	X20-OUT	ERROR-OUT	State
GND	GND	GND	Normal condition
High impedance	GND	GND	$I_{\Delta N1} \geq 5mA_{rms}$
High impedance	High impedance	GND	$I_{\Delta N2} \geq 20mA_{rms}$
High impedance	High impedance	High impedance	Error, system fault

All other conditions not mentioned in the table are not possible. If these conditions occur, the sensor is an unknown state and describes an Error.

Table 1: Possible output states